



EPT20-RASS Electric Pallet Truck 2.0t

Fits the Dual Monitoring of Traveling and Steering Motors International Safety Standard;
Ergonomic Design Offers Perfect Combination of Performance & Safety;
Best Choice for High Efficiency & Heavy Duty Handling Task,
Top Driving Speed (Optional) Reaches 12KM/H.

EP EQUIPMENT CO.,LTD
www.ep-ep.com



FEATURE

Performance

- The innovative AC system offers strong power, accurate control, excellent performance.
- High strength vertical gearbox, longer working life.
- Low-noise but durable hydraulic unit, good quality cylinder as well as hose ensure the high reliability of hydraulic system.
- AMP connector and durable electric wires greatly reduce malfunctions of components.
- One-time formed fork, box type frame and adjustable linkage extends the life of undercarriage.
- High Speed(Up to 12KM/H Unladen): High Efficiency of Material Handling Operations



Safety

- Half-surrounded operator compartment design.
- Side leaning position provides wider view when travel forward and backward.
- Safety foot switch avoids operators from misoperating.
- Automatic braking and reverse current braking when foot switch is off or travel switch is neutral.
- Emergency disconnecter will cut off power source to avoid accident when truck goes out of control.
- Anti-rolling back brake keeps the truck from skidding down when truck is out of control or travelling on ramp.
- Dual-monitoring power steering, the top safety design(electric steering).

Operation

- With the new design of ergonomical tiller head, all buttons are controlled conveniently & comfortably.
- With backrest cushion, support seat, spacious operation room and vibration absorber pedal, operator will feel more comfortable.
- The unique suspension driving floating system(DFA) design, ensures the stability in high speed.
- Side-open battery compartment design for easy replacement and maintenance.
- Electric power steering, smooth & comfortable (EPS).

Maintenance

- AC traction motor, maintenance free.
- Hour meter and battery indicator remind the operator of battery charging.
- Easily remove the back cover by only losing four bolts; Access to all key components for inspection, maintenance and replacement.
- Vertical motor makes the inspection & service much more convenient.
- Control system allows easy trouble-shooting.
- Low voltage lift cut off design protects the battery.

Electric Pallet Truck 2.0t EPT20-RASS

Distinguishing mark				
1.1	Manufacturer			EP
1.2	Model designation			EPT20-RASS
1.3	Drive unit			Electrics
1.4	Operator type			standing
1.5	rated capacity	Q	kg	2000
1.6	Load center distance	c	mm	600
1.8	Load distance	x	mm	958
1.9	Wheelbase	y	mm	1465
Weight				
2.1	Service weight (include battery)		kg	810
2.2	Axle loading, laden driving side/loading side		kg	1166 / 1644
2.3	Axle loading, unladen driving side/loading side		kg	630 / 180
Types, Chassis				
3.1	Tyre type driving wheels/loading wheels			polyurethane / polyurethane
3.2	Tyre size, driving wheels (diameter×width)		mm	Φ230x75
3.3	Tyre size, loading wheels (diameter×width)		mm	Φ85x70
3.4	Tyre size, caster wheels (diameter×width)		mm	Φ130x60
3.5	Wheels, number driving, caster/loading (x=drive wheels)		mm	1 x +2 / 4
3.6	Track width, front, driving side	b ₁₀	mm	510
3.7	Track width, rear, loading side	b ₁₁	mm	370 / 430 / 515
Dimensions				
4.4	Lift height	h ₃	mm	125
4.9	Height drawbar in driving position min./max.	h ₁₄	mm	1200
4.15	Lowered height	h ₁₃	mm	85
4.19	Overall length	l ₁	mm	2255
4.20	Length to face of forks	l ₂	mm	1105
4.21	Overall width	b ₁ / b ₂	mm	730
4.22	Fork dimensions	s/ e/ l	mm	55 x 170 x 1150
4.25	Outside width of the forks	b ₅	mm	540 / 600 / 685
4.32	Ground clearance, center of wheelbase	m ₂	mm	30
4.34.1	Aisle width for pallets 1000 × 1200 crossways	Ast	mm	2902
4.34.2	Aisle width for pallets 800 × 1200 lengthways	Ast	mm	2750
4.35	Turning radius	Wa	mm	2102
Performance data				
5.1	Travel speed, laden/ unladen	km/ h	km/h	9.0 / 12.0
5.2	Lifting speed, laden/ unladen		m/ s	0.051 / 0.060
5.3	Lowering speed, laden/ unladen		m/ s	0.032 / 0.039
5.8	Max. gradeability, laden/unladen		%	8 / 16
5.10	Service brake type			Electromagnetic
Electric engine				
6.1	Drive motor rating S2 60 min		kW	2.5
6.2	Lift motor rating at S3 15%		kW	1
6.3	The maximum allowed size battery		mm	652 x 270 x 680
6.4	Battery voltage/nominal capacity K5		V/Ah	24 / 280
6.5	Battery weight		kg	250
Addition data				
8.1	Type of drive control			AC
10.5	Steering type			Electronic
10.7	Sound pressure level at the driver's ear		dB(A)	74

If there are improvements of technical parameters or configurations, no further notice will be given.
The diagram shown may contain non-standard configurations.

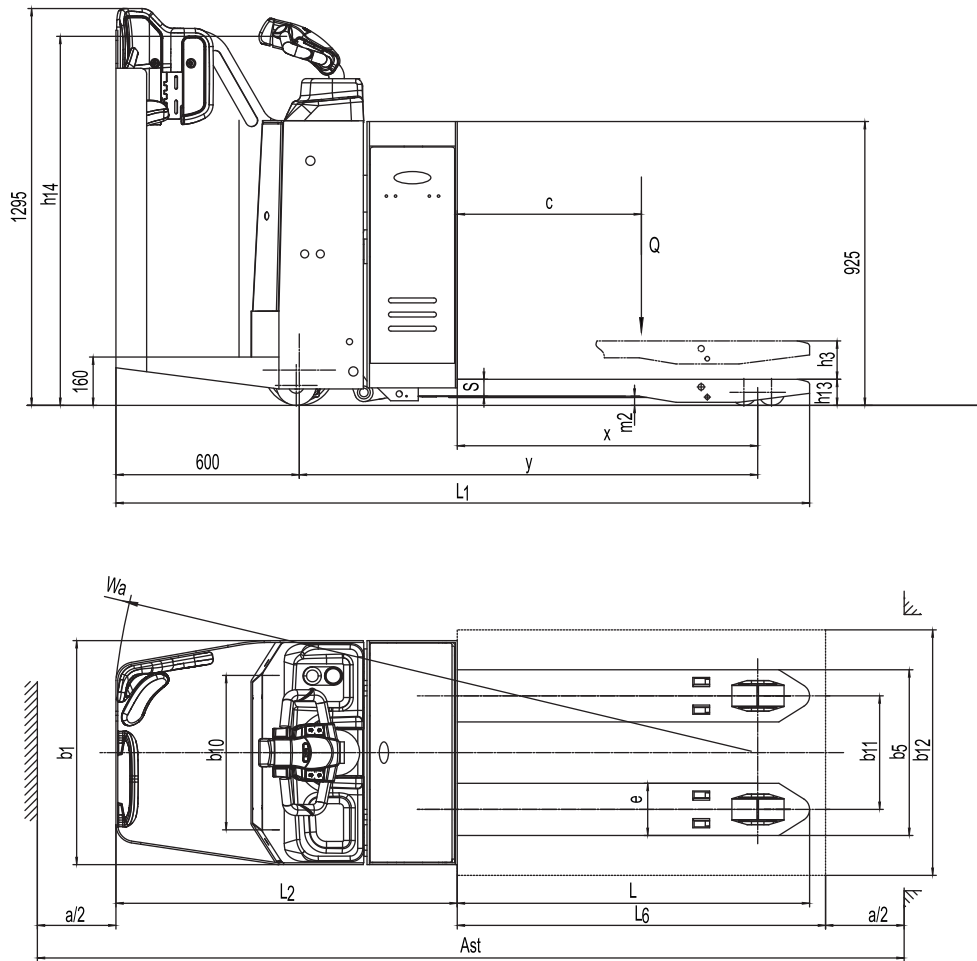

Option

Options	EPT20-RASS
Fork length	○ 1150/1220
Fork width	○ 685/600/540mm
Double load wheel	●
Single load wheel	●
Fork lowered height	—
Driving wheel	●PU
Balance wheel	—
Battery capacity	●
Lateral change battery	○360AH
cold storage	○360AH
Battery indicator without hour meter	○
Battery indicator with hour meter	●
Water auto-filling system	○
Vertical handler working	—
half speed function in turning	●
Guard arm	—
Special backrest	○1220mm (48in)/1520mm (60in)
Note: ●standard ○option —NA	