



EPT20-30RTS EPT20-35RTS Electric Pallet Truck 3.0/3.5t

Pallet Truck with Higher Speed and Greater Capacity;
Provides an ideal choice for Super-tough Working Conditions;
Maximum Capacity Reaches 3.5T and Driving Speed up to 12KM/H;
Dual Pallet Forks Option Doubles Material Handling Efficiency.

EP EQUIPMENT CO.,LTD
www.ep-ep.com



FEATURE



Performance

- The innovative AC system offers strong power, accurate control, excellent performance.
- High strength vertical gearbox, longer working life.
- Low-noise but durable hydraulic unit, good quality cylinder as well as hose ensure the high reliability of hydraulic system.
- AMP connector and durable electric wires greatly reduce malfunctions of components.
- Super high intensity frame design supports high speed, high capacity and long distance applications.
- Adjustable long push rod ensures the stability and lifespan of the truck.

Safety

- Moving parts are far from operator to avoid accidents.
- Operator can freely switch between high speed/low speed switch, by which safety and reliability are greatly enhanced.
- Dual protection arm can assure the operator to be protected in any standing position.
- Emergency reverse belly button protects operator from getting hurt.
- Emergency disconnecter will cut off power source to avoid accident when truck goes out of control.
- Large pedal allows operator to stand fully inside and well-protected.
- Anti-rolling back brake keeps the truck from skidding down when truck is out of control or travelling on ramp.
- Dual-monitoring power steering, the top safety design (electric steering).

Operation

- With the new design of ergonomical tiller head, all buttons can be reached conveniently & comfortably.
- Thanks to the entry roller design, this truck enters and exits pallets easily.
- With the design of ergonomical tiller and buttons, the truck can be operated safely and comfortably under various applications with excellent working view.
- High speed wheel are chosen as standard configuration.
- Can be functional as low level order picker with coast control option.
- Side & top open battery compartment allows various battery option, convenient for replacement and maintenance.
- Electric power steering, smooth & comfortable (EPS).

Maintenance

- AC traction motor, maintenance free.
- Hour meter and battery indicator remind operator of battery charging.
- Easily remove the back cover by only loosening four bolts; Access to all key components for inspection, maintenance and replacement.
- Vertical motor makes the inspection & service much more convenient.
- Control system allows easy trouble-shooting.
- Low voltage lift cut off design protects the battery.



Electric Pallet Truck 3.0/3.5t EPT20-30RTS/EPT20-35RTS

| Distinguishing mark | | | | | |
|---------------------|---|---------------------------------|-------|----------------------------|----------------------------|
| 1.1 | Manufacturer | | | EP | EP |
| 1.2 | Model designation | | | EPT20-30RTS | EPT20-35RTS |
| 1.3 | Drive unit | | | Electrics | Electrics |
| 1.4 | Operator type | | | standing | standing |
| 1.5 | rated capacity | Q | kg | 3000 | 3500 |
| 1.6 | Load center distance | c | mm | 600 | 600 |
| 1.8 | Load distance | x | mm | 1042 | 1042 |
| 1.9 | Wheelbase | y | mm | 1722 | 1722 |
| Weight | | | | | |
| 2.1 | Service weight (include battery) | | kg | 850 | 920 |
| 2.2 | Axle loading, laden driving side/loading side | | kg | 1110/2740 | 1260/3160 |
| 2.3 | Axle loading, unladen driving side/loading side | | kg | 630/220 | 690/230 |
| Types,Chassis | | | | | |
| 3.1 | Tyre type driving wheels/loading wheels | | | polyurethane/ polyurethane | polyurethane/ polyurethane |
| 3.2 | Tyre size, driving wheels (diameter×width) | | mm | Φ254x95 | Φ254x95 |
| 3.3 | Tyre size, loading wheels (diameter×width) | | mm | Φ82.5x165 | Φ82.5x165 |
| 3.4 | Tyre size, caster wheels (diameter×width) | | mm | Φ100x63.5 | Φ100x63.5 |
| 3.5 | Wheels, number driving, caster/loading (x=drive wheels) | | mm | 1x+2/ 2 | 1x+ 2/ 2 |
| 3.6 | Track width, front,driving side | b ₁₀ | mm | 668 | 668 |
| 3.7 | Track width,rear,loading side | b ₁₁ | mm | 456 | 456 |
| Dimensions | | | | | |
| 4.4 | Lift height | h ₃ | mm | 140 | 140 |
| 4.9 | Height drawbar in driving position min./max. | h ₁₄ | mm | 970/1602 | 970/1602 |
| 4.15 | Lowered height | h ₁₃ | mm | 82.5 | 82.5 |
| 4.19 | Overall length | l ₁ | mm | 2325 | 2325 |
| 4.20 | Length to face of forks | l ₂ | mm | 1140 | 1140 |
| 4.21 | Overall width | b ₁ / b ₂ | mm | 915 | 915 |
| 4.22 | Fork dimensions | s/ e/ l | mm | 56/230/1190 | 56/230/1190 |
| 4.25 | Outside width of the forks | b ₅ | mm | 686 | 686 |
| 4.32 | Ground clearance, center of wheelbase | m ₂ | mm | 26.5 | 26.5 |
| 4.34.1 | Aisle width for pallets 1000 × 1200 crossways | Ast | mm | 2984 | 2984 |
| 4.34.2 | Aisle width for pallets 800 × 1200 lengthways | Ast | mm | 2812 | 2812 |
| 4.35 | Turning radius | Wa | mm | 2190 | 2190 |
| Performance data | | | | | |
| 5.1 | Travel speed, laden/ unladen | km/ h | km/h | 10.5/12 | 10.5/12 |
| 5.2 | Lifting speed, laden/ unladen | | m/ s | 0.03/0.033 | 0.028/0.033 |
| 5.3 | Lowering speed, laden/ unladen | | m/ s | 0.040/0.038 | 0.040/0.038 |
| 5.8 | Max. gradeability, laden/unladen | | % | 8/16 | 6/16 |
| 5.10 | Service brake type | | | Electromagnetic | Electromagnetic |
| Electric-engine | | | | | |
| 6.1 | Drive motor rating S2 60 min | | kW | 4 | 4 |
| 6.2 | Lift motor rating at S3 15% | | kW | 2.2 | 2.2 |
| 6.3 | The maximum allowed size battery | | mm | 812x330xopen | 812x330xopen |
| 6.4 | Battery voltage/nominal capacity K5 | | V/Ah | 24/280 | 24/360 |
| 6.5 | Battery weight | | kg | 250 | 320 |
| Addition data | | | | | |
| 8.1 | Type of drive control | | | AC | AC |
| 10.5 | Steering type | | | Mechanical/ Electronic | Mechanical/ Electronic |
| 10.7 | Sound pressure level at the driver's ear | | dB(A) | 74 | 74 |

If there are improvements of technical parameters or configurations, no further notice will be given.
The diagram shown may contain non-standard configurations.

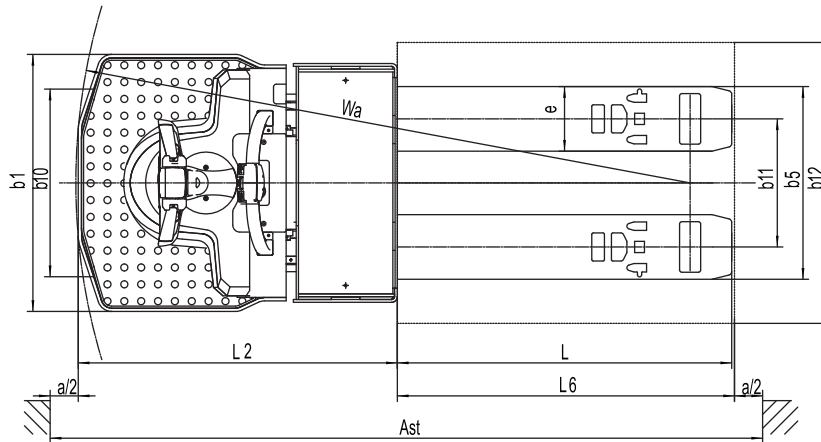
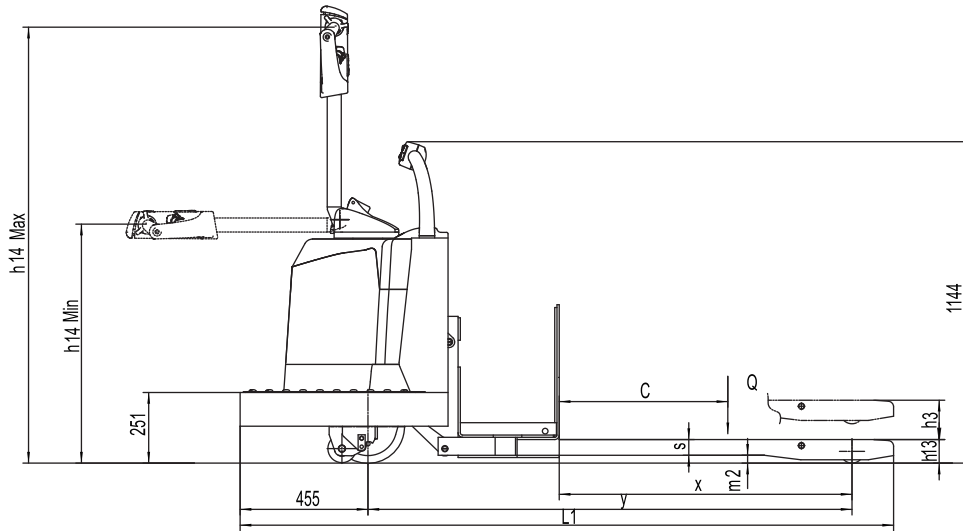

Option

| Options | EPT20-30RTS/EPT20-35RTS |
|--------------------------------------|-------------------------------|
| Fork length | ○ 1190/2428 |
| Fork width | ○ |
| Double load wheel | — |
| Single load wheel | ● |
| Driving wheel | ● PU |
| Balance wheel | ○ |
| cold storage | ○ |
| Battery indicator with hour meter | ○ |
| Battery indicator without hour meter | ○ |
| Battery capacity | ● 360AH |
| Lateral change battery | ○ |
| Water auto-filling system | ○ |
| Vertical handler working | ○ |
| half speed function in turning | — |
| Guard arm | — |
| Fork lowered height | ● 82.5mm |
| Special backrest | ○ 1220mm (48in)/1520mm (60in) |
| Note: ● standard ○ option — NA | |